



Samson



45.8



40.11

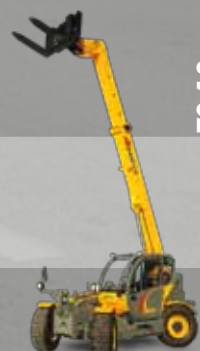

70.10

## PERFORMANCE

	45.8	40.11	70.10
Maximum capacity (kg)	4.500	4.000	7.000
Maximum lifting height (m)	7,90	11,00	9,65
Maximum horizontal outreach (m)	4,45	7,60	5,40
Outreach at maximum height (m)	0,30	1,05	0,70
Fork swivelling angle	134°	134°	134°
Pull-out force (daN)	5.700	5.700	5.700
Towing force (daN)	7.300	7.300	7.300
Maximum climb angle	40%	40%	40%
Total weight empty (kg)	8.800	10.000	11.400
Max speed (km/h)	30*	30*	30*

\* = referred to wheels having the maximum allowable diameter (On request 40 Km/h\*)

## BOOM

	45.8	40.11	70.10
<b>Times: empty / with speed supplement (in seconds)</b>			
Lifting	15,5 / 11,3	15,5 / N.A.	20,7 / 15,1
Descent	10,6 / 7,7	10,6 / N.A.	13,6 / 9,9
Extension	8,1 / 5,9	19,8 / N.A.	14,2 / 10,4
Retraction	4,5 / 3,3	14,4 / N.A.	5,6 / 4,1
Forward swivelling	3,9 / 2,8	3,9 / N.A.	6,4 / 4,6
Reverse swivelling	2,4 / 1,8	2,4 / N.A.	2,8 / 2,0

Patented compensation system

## ENGINE

	Iveco NEF 74 Kw	Iveco NEF 93 Kw
Model:	Iveco NEF	Iveco NEF
Maximum power kW (hp):	74 (101)	93 (127)
Revolutions per minute (rpm):	2200	2200
Operation:	4 stroke diesel	
Injection:	Direct mechanical	
Number and arrangement of cylinders:	4, vertical in line	
Engine size (cm3):	4485	4485
Specific consumption at 2200 rpm (g/kWh):	230	230

Aftercooler Turbo compressor  
Liquid cooling system

## OPTIONALS AND ACCESSORIES

A/C; Webasto Heater; Digital speedometer; Water Heater; Driver's seat with pneumatic suspension; Light on boom head; Quick coupling for accessories; Radio; Anti-theft system; Glass protection.  
(For additional customizations, contact the area dealer)

## TRANSMISSION

Hydrostatic transmission with variable displacement pump.  
Hydrostatic engine with automatic variation.  
Electrical - hydraulic inversion.  
Inching pedal for controlled advancement.  
Servocontrolled 2-speed gearbox.

## HYDRAULIC PLANT

Gear pump with capacity at max. speed (lt/1'):	110
Max operational pressure (bar):	230
Distributor control with joystick:	3 in 1

## DIFFERENTIAL AXLES

Steering axles: 2, with planetary reduction gears
Steering types: 4 wheels / transversal / 2 wheels
Front axle: rigid (levelling upon request)
Back axle: oscillating
Oil bath service braking on the 4 wheels with double hydraulic plant and servo brake
Negative action parking brake

## DEVICES AS PER STANDARD

Anti-tipping device with pejorative movement block.  
Hydraulic socket for any accessories on the boom head.  
Soundproof closed cab, ROPS-FOPS approved, with heater.  
Self-blocking front axle differential (limited slip 45%).  
Electric window winder.

**Only on the following models: 40.11**

Independent hydraulic tipping outriggers

## REFUELLING (Litres)

	45.8	40.11	70.10
Hydraulic plant (total)	155	170	160
Fuel tank	105	105	105

## TYRES

	45.8 40.11	70.10
Tyres	405/70x20"	18/22.5"
Alternative	405/70x24"	/

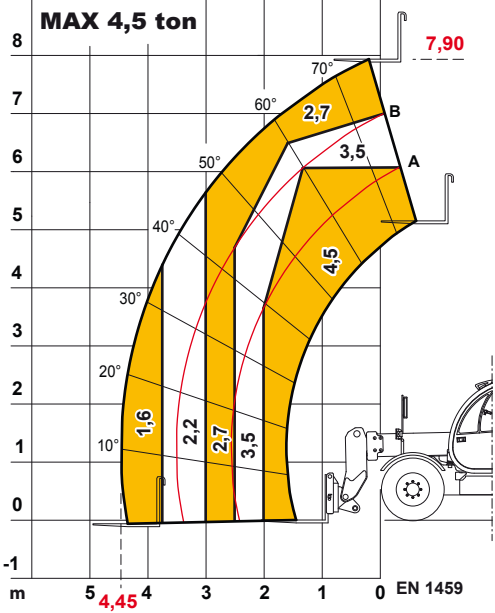

**Samson 45.8**

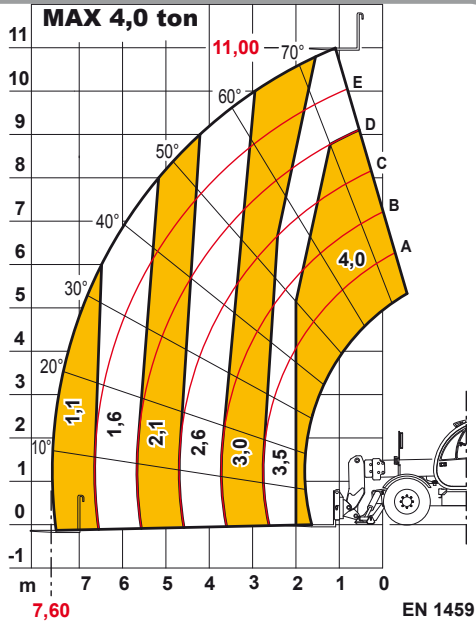

**Samson 40.11**

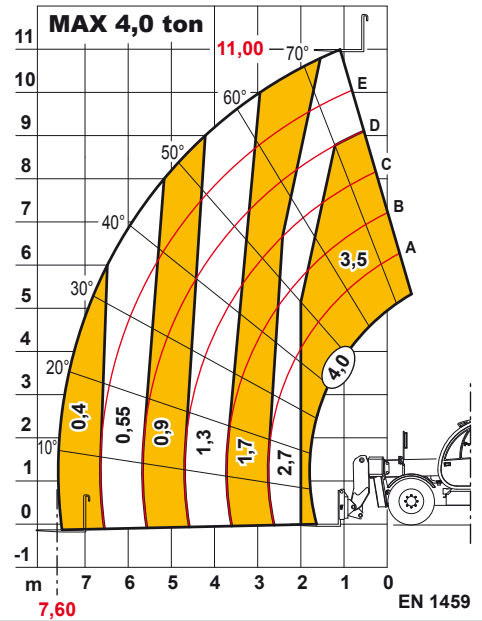

**Samson 40.11**



**OPTIONAL**

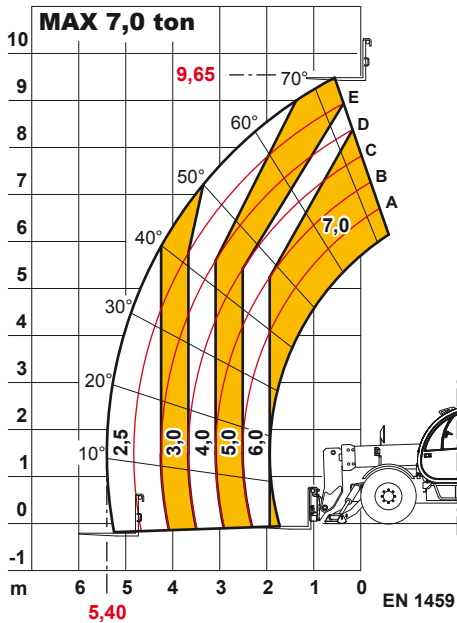

**Samson 70.10**

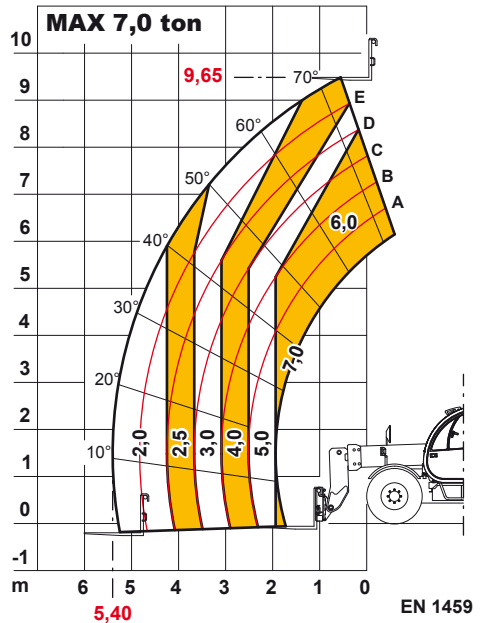

**Samson 70.10**

## Accessories and Attachments specific for any need

Mixing bucket

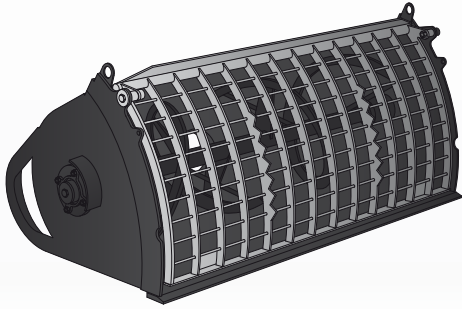

Bucket for light materials

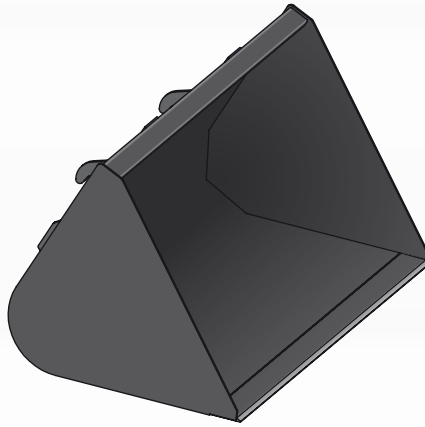

Winch

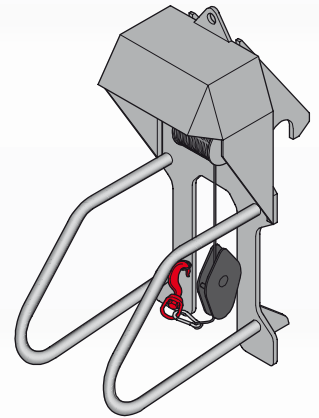

Winch jib crane extension

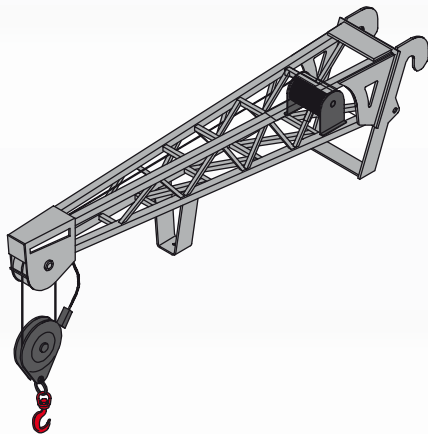

Orange-peel grab

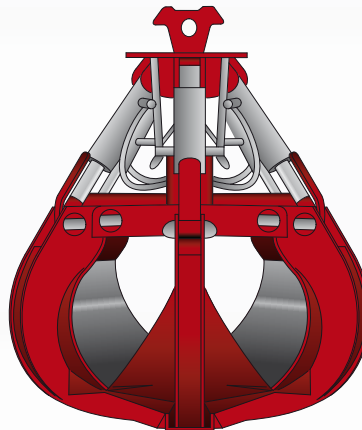

Ladle

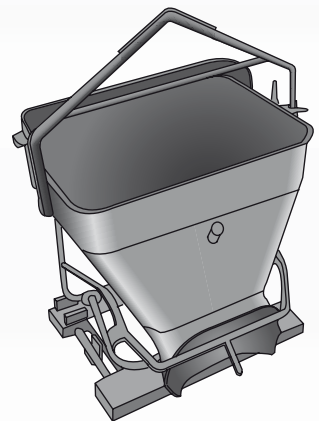

Swan neck jib

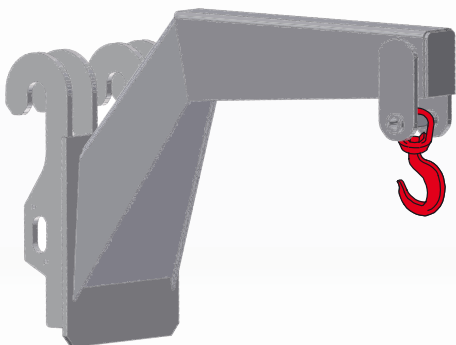

Materials basket



Hook

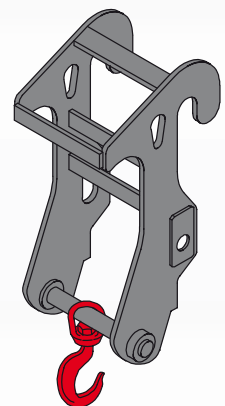

This is only a part of the many accessories and various equipment available for Dieci machines.  
For information about the entire range of accessories **CONTACT US** using contact information contained on the rear of the document.



### 360° Visibility

From the significantly raised driver's seat, the innovative anti-fall protection system, located inside the cab, allows for a 360° view that is without comparison.

Two independent rear-view mirrors on both sides reduce blind spots to a minimum.



### Comfort

A telescopic lift that takes care of everything... You will notice it immediately, equipped with the largest door on the market, accessing the driver's seat will no longer be a problem. The inside of the cab has been entirely designed in order to make work easier for the operator. Thanks to the integration of the armrest in the right instrument panel, it both reduces arm stress and provides greater accessibility to the joystick. The precise distribution of the ventilation grills optimises efficiency of the heating and air conditioning system, providing a perfect distribution of air inside of the cab.



### Engine: low consumption, high yield

Designed for intense use, they guarantee a high level of reliability over time. The new TIER III engines guarantee remarkable elasticity providing maximum power, even at low engine speed and an unparalleled low operational noise level.

This, along with the possibility of equipping the machine with a particle filter, provides for drastic reduction of consumption.



### Safety

For us, safety is an absolute priority, it is guaranteed by an electronic system, standard on all models, which makes it possible to always keep the weight on the forks or on equipment under control during work manoeuvres.

The load limiter flexibly and accurately manages both standard equipment and that used for specific applications.



### Design

Dieci has always considered design a significant aspect when engineering their own products.

This philosophy is evident when considering the newly designed cab and chassis restyling.

Paying particular attention, Dieci engineers have been able to interpret the request of a comfortable and functional compartment, creating a spacious and ergonomic cab with snappy styling.



### Great agility and reduced steering radius

One of the characteristics that distinguish Dieci telescopic devices the most is workability. The extremely reduced steering radius combined with high capacity axles make the machine both agile and powerful. The four drive wheels and the possibility of steering the wheels in three different modes, make it possible to operate on any type of land. Muddy ground, mountain areas, tight spaces and many other extreme conditions will no longer be an obstacle.

## DIMENSIONS

	45.8	40.11	70.10
A/A*	440/480*	440/480*	440
B	1480	1660	1630
C	2600	2600	2950
D	860	860	1330
E/E*	4000/4050*	4000/4050*	4820
F	4940	5090	5910
G	940	940	940
H/H*	2460/2500*	2460/2500*	2490
I	1910	1910	1920
L	2310	2310	2380
M	N.A.	2480	2700
N	4080	4200	4730
O	1260	1260	1700
P	3920	3920	4400

Measurements expressed in millimetres

A\* - E\* - H\* = Measurements referring to optional wheels

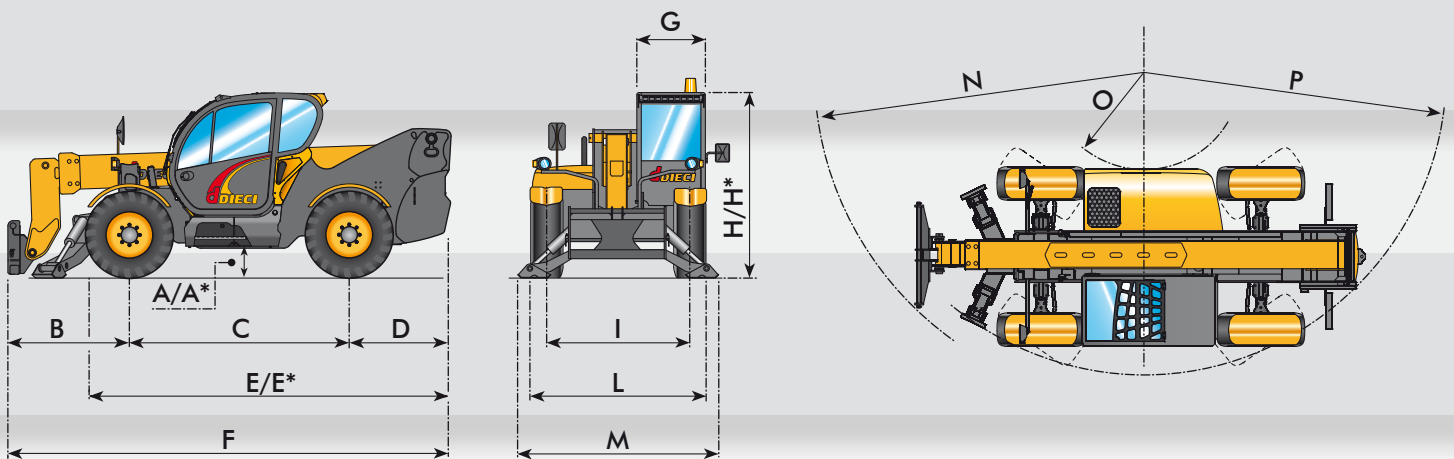

A\* - E\* - H\* = Measurements referring to optional wheels



**d** **DIECI**  
macchine edili ed agricole  
S.p.A.

Via E. Majorana, 2-4 42027 Montecchio Emilia (RE) ITALY

Tel. +39 0522 869611 Fax +39 0522 869791 (comm. le Estero) Fax +39 0522 869604 (comm. le Italia)

[www.dieci.com](http://www.dieci.com) - E-mail: [info@dieci.com](mailto:info@dieci.com)